



A Geno Technology, Inc. (USA) brand name

Sample Concentrator

Cat. No. BT1603

Thanks for choosing BT Lab Systems' Sample Concentration. This operation manual describes the function and operation of the instrument. In order to use the instrument properly, please read this manual carefully.

IMPORTANT SAFETY INFORMATION

- Please read this operation manual carefully before using the instrument.
- This product is an indoor Instrument.
- These units are designed for laboratory use by persons knowledgeable in safe laboratory practices.
- The operator should never open or repair the instrument. Opening or repairing the instrument will void the guarantee and can cause accidents.
- The power plug should safeguard against an electric shock. The 3-pin plug supplied with the instrument should be matched with a suitable grounded socket.
- The temperature of metal block will be very high during the normal operation. The liquid will be boiling. Do not touch any part of the body to the instrument due to risk of scalding.
- Close the test tube lid before putting the tube into the block. Liquids may spill out in the block or onto the device if the tube lid is opened, which will damage the block or the device.
- Make sure the rated electrical outlet load is no lower than the demand. Power line should be replaced with the same type if it is damaged. Make sure there is nothing else on the power line. Hold the jack when pulling out the power line. Do not pull the power line. Do not put the power line in a place where there is a tripping hazard.
- The instrument should be used in an area with low temperature, little dust, no water, no sunshine or hard light and with good air circulation. Do not use where there is corrosive gas or a strong magnetic field. Keep far away from central heating, camp stove and other hot sources. Do not put the instrument in a wet and dusty area. The vent on the instrument is designed for aeration. Do not wall up or cover the vent. The distance between each device should be more than 100cm when there is more than one instrument.
- Power off when not in use. If the instrument will not be used for a long period, unplug, and cover with a piece of cloth to protect it from dust.
- In case of the following, unplug the instrument at once and contact BT Lab Systems.
 - The instrument comes into contact with liquid
 - The instrument gets soaked or burned
 - The instrument emits an abnormal sound or smell
 - The instrument is dropped or the outer shell damaged
 - The instrument functions abnormally.

MAINTENANCE

The well in the block should be cleaned by a cloth dampened with alcohol to assure good heat translation between the block and the test tube and no residue. If there are smudges on the instrument, clean it with a dry cloth.

Power off when cleaning the instrument. Do not drop the cleaning fluid in the well when cleaning. Do not use corrosive cleaning fluid.

WARRANTY

The instrument is warranted against defects in materials and workmanship for 1 year. If any defects occur in the instrument or accessories during this warranty period, BT Lab Systems will repair or replace the defective parts at its discretion without charge.

For any inquiry or request for repair service, contact your local BT Lab Systems office. Inform BT Lab Systems of the model and serial number of your instrument.

INTRODUCTION

The nitrogen sample concentrator is mainly used for concentrating or preparing samples in batches such as drug screening, hormone analysis, liquid phase and mass spectrometry in the analysis of sample preparation. It works by blowing nitrogen in the surface of the sample which is being heated to accelerate evaporating and separating the solvent in the samples without oxygen. Instead of the rotary evaporation instrument, nitrogen sample concentrator can efficiently concentrate dozens of samples simultaneously.

KEY FEATURES

- The instrument works with heating by dry bath in the bottom and blowing nitrogen on the surface which accelerates liquid evaporation and sample concentration.
- The position of the gas needle in air chamber plate can be adjusted to suit for different types of tubes.
- The height of the air chamber plate can be adjusted. The length of a standard gas needle is 150mm.
- Gas needle is controlled independently. Separate blowing of each needle and flow regulating of each needle are available to avoid gas waste.
- The instrument can be put into ventilation cabinet when the concentration sample is toxic solvents.
- Built in overheat protection, automatic fault detection and fault beep alarm devices.
- LED displays immediate temperature and diminishing time. Operation is simple and convenient.
- Standard configured air cavity and adjustable bracket.

NORMAL OPERATING CONDITIONS

Ambient temperature: 5°C ~30°C

Relative humidity: ≤ 70%

Power supply: AC110V ~ 50-60Hz

TECHNICAL SPECIFICATIONS

Temperature Range	R.T.+5°C ~ 150°C
Heating Time	≤30min (from 40°C to 150°C)
Temperature Accuracy (40~100°C)	±0.5°C
Temperature Accuracy (100~150°C)	±1°C
Temperature Uniformity (100°C)	±0.5°C
Blocks Quantity	1 block
Time Range	99h 59min
Nitrogen Flow Rate	0~10L/min
Nitrogen Pressure	≤0.1MPa
Power	400 W
Dimensions (mm)	260 x 200 x 520

OVERVIEW

This section describes the instrument's mechanical structure, the keyboard and functions of each key, as well as preparation before turning the power on. Please learn this section well before operating the instrument for the first time.

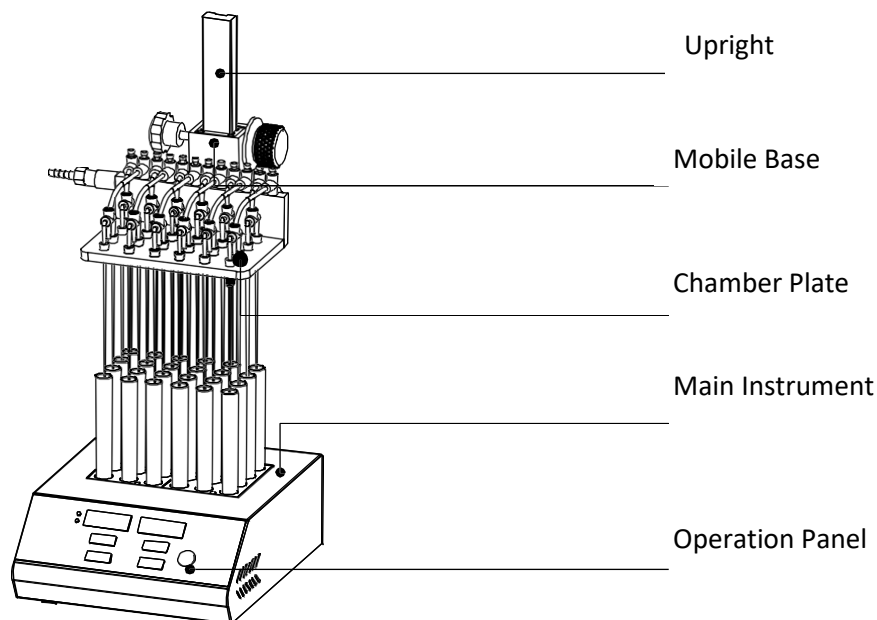

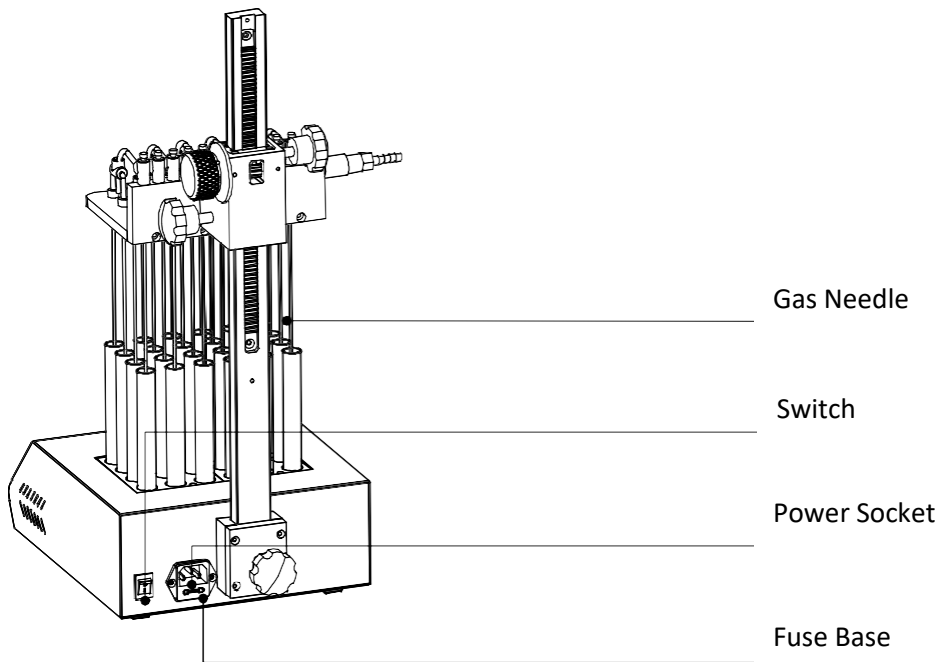

INSTRUMENT INSTALLATION

Assembly

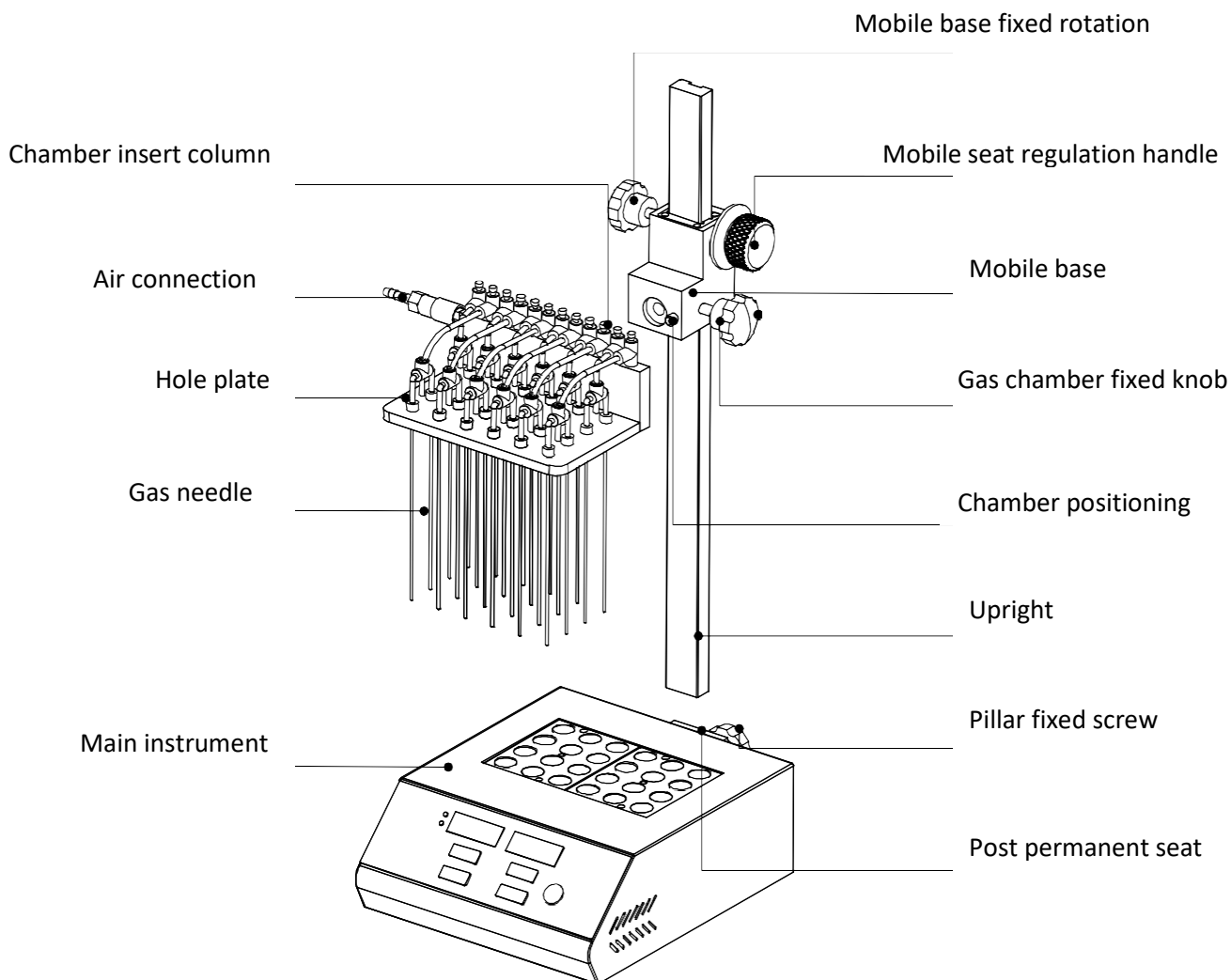

Installation Steps

1. Put the instrument on a solid and stable bench.
2. Fully insert the column into the square hole of the column holder behind the instrument, then screw knob into the column mounts, and finally tighten the knob to secure the uprights.
3. Screw fixed knob of the mobile seat into the threaded hole on the left side of the mobile seat, then hold knob of mobile seat and rotate the hand wheel adjustment counterclockwise. When you have reached the desired position, tighten the knob to fix mobile seat. Rotating the hand wheel adjustment clockwise, the mobile seat will move down (as shown in the picture).

Note: When moving the seat, two hands must be used in conjunction with operating mobile seat fixed knob and hand wheel adjustment.

4. Screw fixed knob of the gas chamber into the threaded hole on the left side of the movable block, then insert column of gas chamber into the corresponding hole of the front movable block. Fully insert column of gas chamber, then tighten fixed knob. (as shown in the picture)

Gas Needle Installation

1. Tighten the gas needle clockwise into the hole plate. If there are extra holes, close the throttle so as not to waste gas.

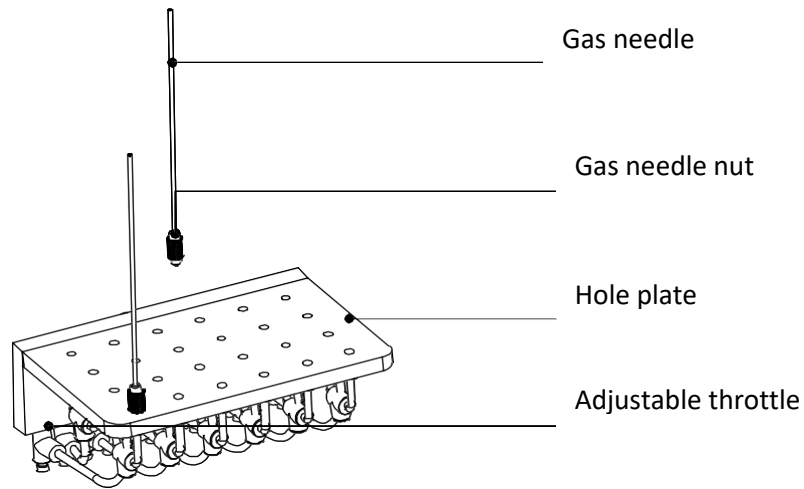

2. After installing air needle, then flip the gas chamber and insert into the mobile base, to affix the gas chamber with knob.
3. With the Quick Connection on the part of gas joint, so users can easily and quickly pass snuff source. Do the following:

Tighten part 2(Connector), Target 1(Admission piece), force in the direction of arrow A. The spring parts within the connector will tighten automatically to part 1(Admission piece). Press part 2 in the direction of arrow B, the spring member within the connector will automatically disengage. Trachea separates from the gas distribution chamber.

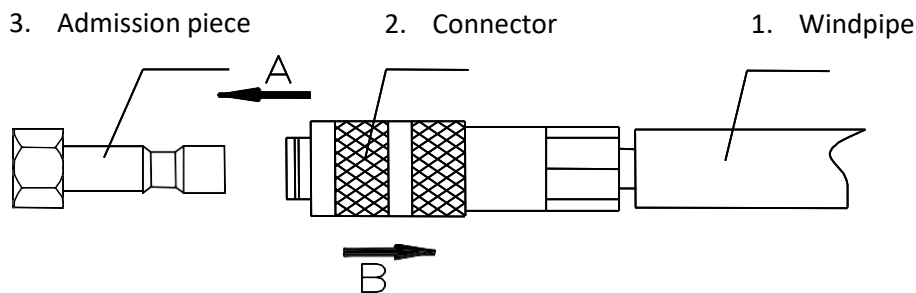

4. Loosen the knob and turn the hand wheel adjustment till the gas needle is inserted into the top of the test tube about 10mm above the fluid. Then fix and tighten mobile base.
5. Turn on the gas source when needed.

Note: Don't turn the input gas pressure greater than 0.08Mpa. This causes gas chamber's bad seal and leak, thus waste of the gas. Keep the gas pressure lower than 0.04Mpa, when the gas needle number is less than 16.

Installation of nitrogen flow rate adjusting valve

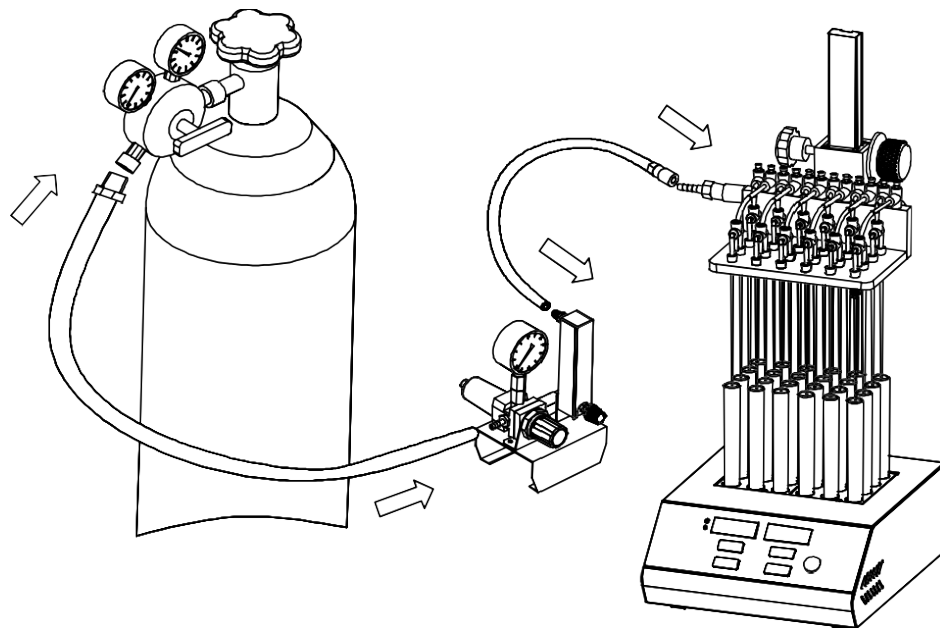

As in the above picture, connect the outlet of the nitrogen flow regulator valve with outlet port of the instrument with a short hose (about 1.5m). Connect the inlet of nitrogen flow regulator valve with outlet port of the instrument with a long hose (about 3m)

Note: Slowly open the valve of the nitrogen bottle to control the outlet pressure between 0.1MPa to 0.2MPa, and then open the valve adjusting knob to keep pressure value at 0.02MPa. According to the number of holes, we can adjust the pressure appropriately (usually between 0.02MPa and 0.05MPa).

OPERATION PANEL

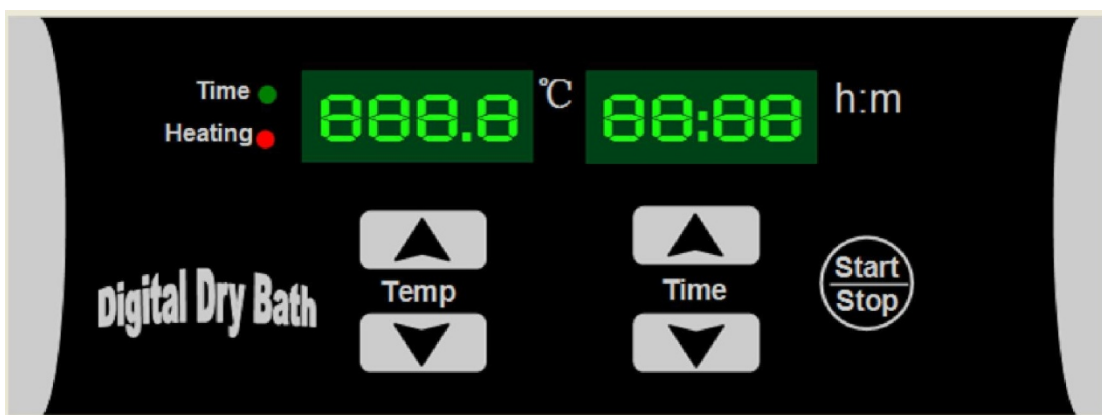

KEY FUNCTION

“DOWN” arrow	Decreasing button: decreases the value
“UP” arrow	Increasing button: increases the value
Start/Stop	Run/stop button: start operation by pressing the button after setting the temperature and the time value. Press this button for 2 seconds to stop the instrument in operation.

Temperature and Time Setting

1. Power on, the LED displays “8” . The instrument enter to the initial state
2. Two seconds later, the value changes to block current temperature and setting time of last operation.
3. Click “UP” or “DOWN” arrow of temperature, the temperature value changes to the setting value in last operation, and the last digit of the setting value flickers. Press “UP” or “DOWN” arrow of temperature to change the temperature setting value. When the value reaches the target, release “UP” or “DOWN” arrow, the instrument automatically confirms and saves the value.
4. Click “UP” or “DOWN” arrow of time, the last digit of the time setting value flickers. Press “UP” or “DOWN” arrow of time to change the time setting value. When the value reaches the target, release “UP” or “DOWN” arrow, the instrument automatically confirms and saves the value.

Note: The time setting “00:00” means no operation timing, the instrument runs continuously at the setting temperature.

Start/Stop

1. After setting the temperature and time, click the Start/Stop key to start the instrument operation. The temperature will rise. Press “start/stop” to run the program after setting time and temperature value. When program completes, instrument stops running and alerts.

When the instrument is heating, the dot “.” of the temperature value flickers. When the temperature reaches the setting value, the dot “.” stops flickering, and the colon “:” of the time value begins to flicker, meanwhile, the time is in countdown.

When the time is up, the operation stops with buzzer alarm. LCD displays current block temperature and time display is “OVER” which means the operation is completed.

2. When the operation completes, the instrument goes to waiting interface. Press “UP” or “DOWN” arrow to reset the temperature and time, then, press start/stop to start a new operation. Press start/stop without any change of the setting to restart the operation.
3. Continuously press start/stop for 2 seconds during the operation to stop running. Press start/stop again to continue the operation.

TEMPERATURE CALIBRATION

The temperature of the instrument has been adjusted before it is sold. If there is a deviation between the actual temperature and the displayed temperature, you can do as follows to calibrate it.

NOTICE:

The instrument uses two temperature adjustments to ensure its accuracy. It is linearly adjusted on 40 °C, and 100 °C. The temperature accuracy will be within ± 0.5 °C after the temperature calibration. Both the environmental and the block temperature should be lower than 35 °C when calibrated.

Adjustment Methods

1. Start up the instrument, it enters waiting interface. Make sure the current temperature in display is below 35 °C. If the temperature is higher than 35 °C please wait until it is below 35 °C.
2. Inject olefin oil into one of block wells. Put a thermometer into this well (the precision of the thermometer should be 0.1 °C. The temperature ball should be immersed into the block well). Adiabatic material is needed on the block to separate it from the oil.

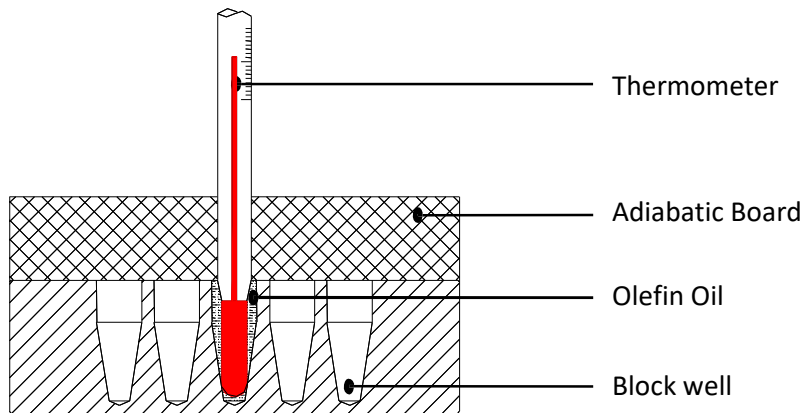

NOTICE: To ensure the calibration precision, read the actual temperature and allow 20 minutes for the temperature to reach calibration point.

3. Press “UP” and “DOWN” arrow simultaneously to enter the temperature calibration interface. LED displays “ADJT” in the time display, the temperature displays the current temperature and the program auto controls the temperature to 40 °C.

When the temperature reaches 40 °C, the decimal digit begins to flicker. Wait for at least 20 minutes, press “UP” or “DOWN” arrow of temperature to amend the temperature value to the actual temperature of the thermometer. Press “Start/Stop” to confirm.

Program saves the value. Temperature rises to 100 °C automatically.

4. When the temperature reaches 100 °C, the decimal digit begins to flicker. Wait for at least 20 minutes, press “UP” or “DOWN” arrow of temperature to amend the temperature value to the actual temperature of thermometer, Press “Start/Stop” to confirm.

5. After temperature have been adjusted, press and “UP” and “DOWN” arrow simultaneously to exit the temperature calibration and return to waiting interface.

Notice: After temperature calibration, the temperature display is the same as the practical temperature of block.

Press “UP” and “DOWN” arrow simultaneously during the calibration to exit the adjustment procedure, the calibration is invalid.

Exchange of Block

1. Pull out the two screws which attach the block to the heating board with the screwdriver.

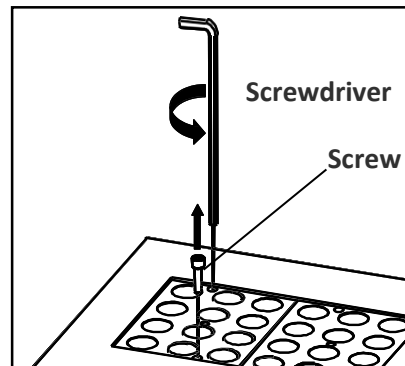

2. Put the raiser in the center well of the block.

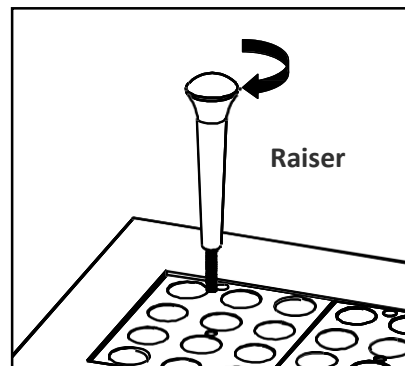

3. Pull out the block with the raiser.

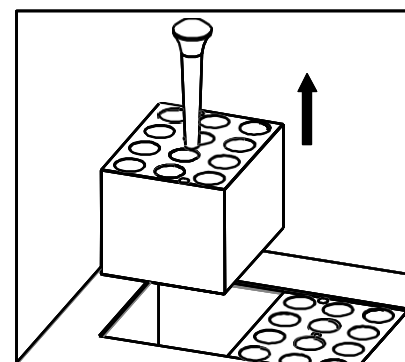

4. Remove the raiser from the block, then attach the raiser to the replacement block. Put the block in the instrument and attach it with screws. Please be patient. This process is complicated.

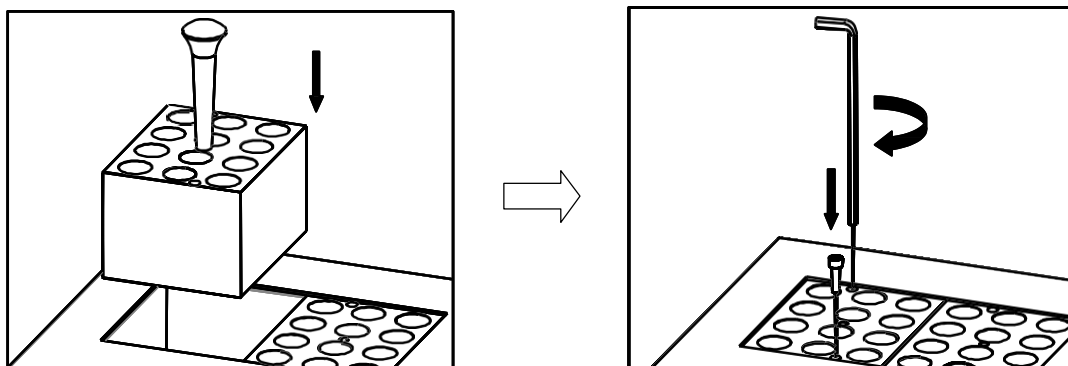

TROUBLESHOOTING

Issue	Possible Causes	Solution
No signal display when power-is turned on.	No power	Check the power connection.
	Broken Fuse	Exchange fuse (250V 4.0A Φ 5x20)
	Broken Switch	Exchange the switch
	Other	Contact BT Lab Systems
The actual and displayed temperatures are different.	Broken sensor or loose contact to the block	Contact BT Lab Systems
“ERR” in the display with an alarm sound.	Broken sensor or room temperature is below zero	Contact BT Lab Systems
Block doesn't heat.	Broken sensor	Contact BT Lab Systems
	Solid state relay damage	
	Broken heater	
Key does not work	Key is broken	Contact BT Lab Systems

TECHNICAL SUPPORT

BT Lab Systems offers technical support for all of its products. If you have any questions about the product's use or, operation, please contact BT Lab Systems at the following:

E-Mail: info@BTLabSystems.com