



A Geno Technology, Inc. (USA) brand name

Digital Overhead Stirrer

Cat. No. BT1021

Thanks for choosing BT1021 Digital Overhead Stirrer. This operation manual describes the function and operation of the instrument. Please read this manual carefully before operating the instrument.

IMPORTANT SAFETY INFORMATION

Users should understand how to use the instrument properly before operating it. Please read this operation manual carefully before using the instrument.

The operation, maintenance and repair of the instrument should comply with the basic guidelines and warning below. Ignoring these instructions will affect the life of the Instrument and safety precautions.

- This product is an indoor Instrument which conforms to Standard B style- I type- GB9706.1.
- Before operation, read the manual carefully. These units are designed for using in laboratory environments by persons knowledgeable in safe laboratory practices.
- The operator should never open or repair the instrument. Opening or repairing the instrument will void the guarantee and can cause accidents.
- The power plug should safeguard against an electric shock. The 3-pin plug supplied with the instrument's power cable is a safety device that should be matched with a suitable grounded socket
- The instrument should be used in an area with low temperature, little dust, no water, no sunshine or hard light and with good air circulation. Do not use where there is corrosive gas or a strong magnetic field. Keep far away from central heating, camp stove and other hot sources. Do not put the instrument in a wet and dusty area. The vent on the instrument is designed for aeration. Do not wall up or cover the vent.
- Power off when not in use. If the instrument will not be used for a long period, unplug, and cover with a piece of cloth to protect it from dust.
- In case of the following, unplug the instrument at once and contact BT Lab Systems.
 - The instrument comes into contact with liquid
 - The instrument gets soaked or burned
 - The instrument emits an abnormal sound or smell
 - The instrument is dropped or the outer shell damaged
 - The instrument functions abnormally.

MAINTENANCE

The instrument and the accessories should be cleaned with a cloth dampened by alcohol. If there are smudges on the instrument, clean it with a dry cloth.

INTRODUCTION

The Digital Overhead Stirrer is suitable for middle and high viscosity liquids or solid-liquid mixtures. It is used in chemical synthesis, pharmaceutical, physical and chemical analysis, petrochemical, cosmetics, health products, food and biotechnology.

KEY FEATURES

- Backlit LED displays speed and time.
- Precise control speed, accuracy within 3rpm. Display show actual/setting speed.
- Consistent speed. Torque is automatically adjusted according to the sample viscosity to keep the setting speed.
- Smooth start to effectively prevent spilling.
- Closed shell to prevent liquid from entering the machine's internal circuit, ensures safe operation. Long service life and stable operation.
- Overload protection and motor protection. Circuit auto cut-off when overload, short circuit and abnormal speed occur.
- Clockwise and counterclockwise stirring exchange mode.

NORMAL OPERATING CONDITIONS

- Ambient Temperature: 4°C ~45°C
- Relative Humidity: ≤70%
- Power: AC90-230V

TECHNICAL SPECIFICATIONS

- Max. Stirring Load (H₂O): 40L
- Timing Range: 30s ~999min
- Speed Range: 50rpm ~2200rpm
- Speed Accuracy: ± 3rpm
- Speed Display Accuracy: ± 1rpm
- Max. Torque: 60 N.cm
- Max. Viscosity: 50000mPas
- Drill Chuck Clamping Diameter Range: 0.5 ~10mm
- Voltage: VD 24V, 50/60Hz
- Power: 130 W
- Dimension: 83 x 220 x 186 mm
- Net Weight (main instrument): 2.8 kgs

EQUIPMENT OVERVIEW

This section describes the instrument's mechanical structure, the keyboard and functions of each key, as well as preparations before the power is turned on. Please learn this chapter before the instrument is to be operated for the first time.

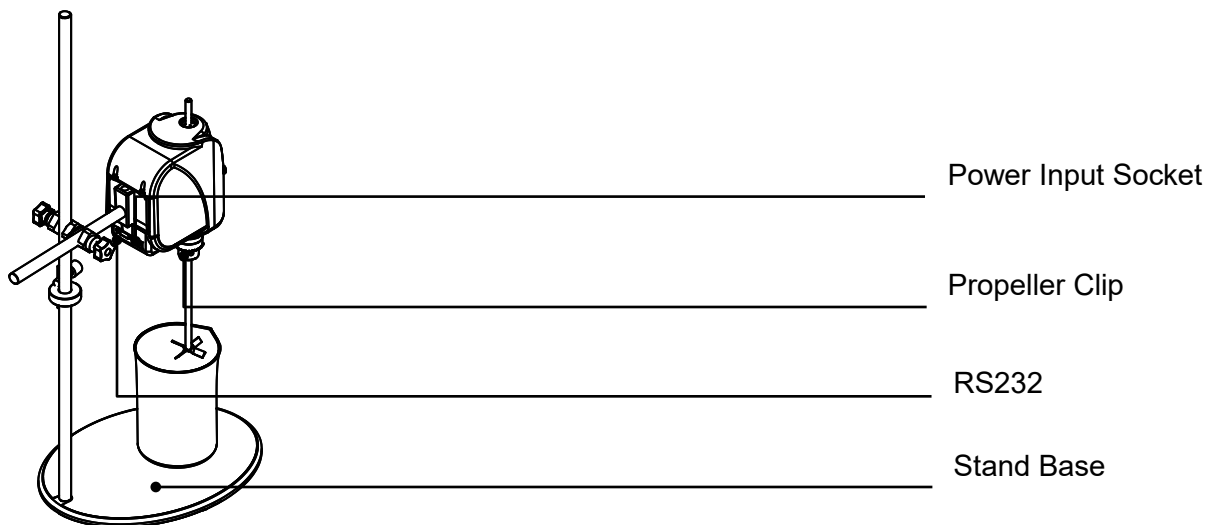

KEYBOARD AND DISPLAY PANEL

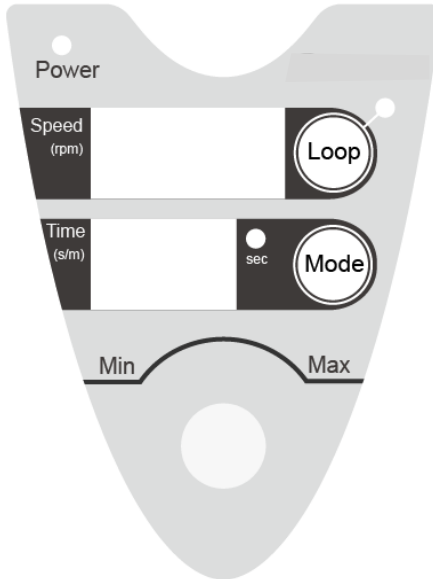

Key Function

1. Rotate the knob clockwise to increase the value that is flickering, rotate the knob counterclockwise to decrease the value that is flickering. Press the knob to start or stop the operation.
2. Press the Loop key, the red loop light on the side turns on. The instrument stirs clockwise and counterclockwise according to the setting time.
3. Press the Loop key again, the loop light on the side turns off. The instrument only stirs clockwise.
4. Before operation, press the Mode key to move the digital read out position.
5. During operation, when under Loop mode, press the Mode key to display interval time (the green light at the side is on), or to display total operation time (the light at the side is off).

Installation

1. Put the stand base on a steady, horizontal work table.
2. Put the stand rod through the check ring (refer to figure 1). Adjust the position of the check ring until the hole on its side lines up with the hole in the middle of the rod, twist the screw clockwise to attach the checking ring and the rod.
3. Attach the stand rod to the stand base with supplied nut (refer to figure 2 and figure 3).

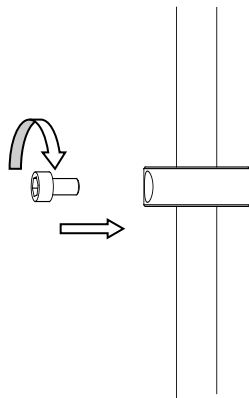

Figure 1

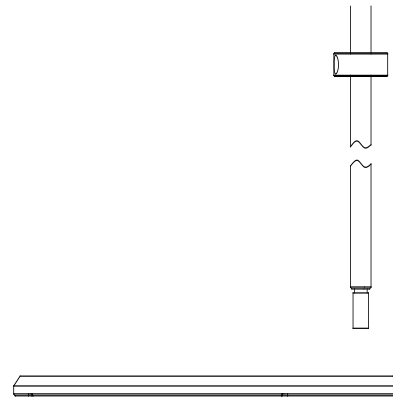

Figure 2

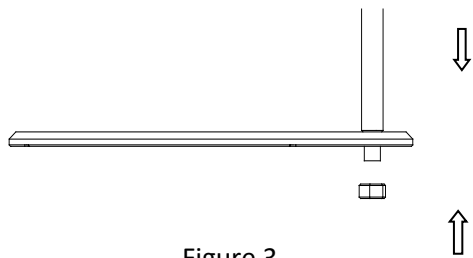

Figure 3

4. Attach the bar to the main instrument, twist the screw from above to attach the bar to the main instrument (refer to figure 4).

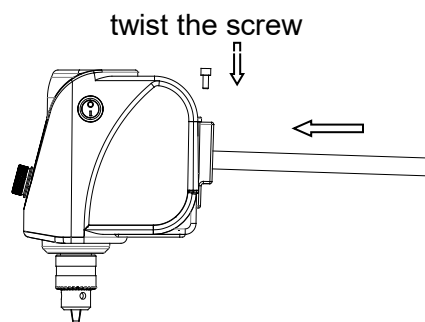

Figure 4

5. Put the bar in the right groove of the active block, use the knob to adjust it. (refer to figure 5).

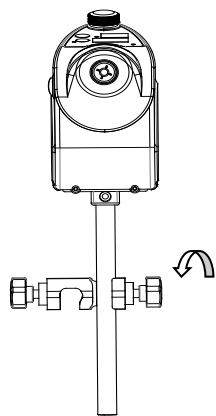

Figure 5

6. Put the stand rod in the left groove of the active block, use the knob adjust it. (refer to figure 6).

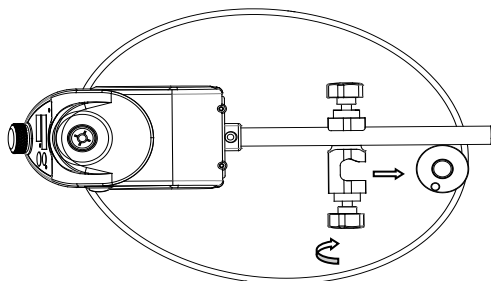

Figure 6

7. Insert the stir propeller in the propeller clip, rotate the clip clockwise until the propeller is tightly attached to the main instrument (refer to figure 7).

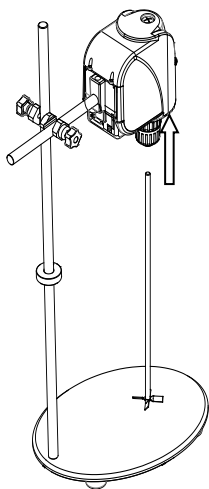

Figure 7

Notice: The position of the main instrument can be adjusted by the active block

OPERATION

Speed and Time Setting

1. When the instrument is turned on, the display screen will show “ 8 ”. The instrument goes into the initial program with a beep.
2. The Speed LED displays the last running speed. Press the Mode key, the last digit flickers. Rotate the knob clockwise to increase the speed value, Rotate the knob counterclockwise to decrease the speed value. Press the Mode key again, the 3rd digit flickers, rotate the knob to increase/decrease the speed value by tens. Press the Mode key again, the 2nd digit flickers, rotate the knob to increase/decrease the speed value by hundreds.
3. Press the Mode key again, the last digit of time value flickers. The Time LED displays last setting time. Press the Mode key after the 2nd digit of speed flickers, the last digit of time value flickers. Rotate the knob clockwise to increase the time value, rotate the knob counterclockwise to decrease the value. Press the Mode key again, the 2nd digit of time value flickers, rotate the knob to increase/decrease the time value by tens. Press the Mode key again, the 1st digit flickers, rotate the knob to increase/decrease the time value by hundreds.
4. Press the Mode key again, the last digit of speed value flickers.

If it is under Loop mode (the red light at the Loop side is on), press Mode key again, the green light at the time LED display side is on. There are only 2 digits displayed on the time screen now, the last digit flickers. This is the time value of the stirring time. It shows the seconds for stirring in 1 direction. Rotate the knob clockwise to increase the time value, rotate the knob counterclockwise to decrease the value. Press the Mode key again, the 1st digit flickers, rotate the knob to increase/decrease the time value by tens.
5. Before the speed reaches the setting value, the green power light flickers. When the speed reaches the setting value, the green power light stays on.

NOTICE: Setting the time value at “000” means running time is continuous.

Stop/Start

1. After setting the speed and time value, press the knob to start operation.
2. Press the knob during operation to stop running.
3. When time is up, the instrument stops running and a beep alert sounds.

TROUBLESHOOTING

Issue	Possible Causes	Solution
No signal display when power is turned on.	No power	Check the power
	Broken switch	Exchange the switch
	Other	Contact BT Lab Systems
Abnormal vibration during operation	Sample not placed in the middle	Place the sample in the middle
Actual speed and displayed speed are not matching	Broken controller	Contact BT Lab Systems
Display ERR	Speed out of control	Contact BT Lab Systems
Knob does not work	Broken knob	Contact BT Lab Systems

WARRANTY

The BT1021 DIGITAL OVERHEAD STIRRER is warranted against defects in materials and workmanship for 1 year. If any defects occur in the instrument or accessories during this warranty period, BT Lab Systems will repair or replace the defective parts at its discretion without charge. The following defects, however, are specifically excluded:

1. Defects caused by improper operation.
2. Repair or modification done by anyone other than BT Lab Systems or an authorized agent.
3. Damage caused by substituting alternative parts.
4. Use of fittings or spare parts supplied by anyone other than BT Lab Systems.
5. Damage caused by accident or misuse.
6. Damage caused by disaster.
7. Corrosion caused by improper solvent or sample.

This warranty does not apply to parts listed below:

1. Fuses
2. Lamps
3. Starters

For any inquiry or request for repair service, contact your local BT Lab Systems office. Inform BT Lab Systems of the model and serial number of your instrument.

REGULATORY NOTICE

IMPORTANT: This BT Lab Systems instrument is designed and certified to meet safety standards and EMC regulations. Certified products are safe to use when operated in accordance with the instruction manual. This instrument should not be modified or altered in any way. Alteration of this instrument will:

1. Void the manufacturer's warranty
2. Void the safety and EMC certification
3. Create a potential safety hazard

BT Lab Systems is not responsible for any injury or damage caused by the use of this instrument for purposes other than those for which it is intended, or by modifications of the instrument not performed by BT Lab Systems or an authorized agent.

TECHNICAL SUPPORT

BT Lab Systems offers technical support for all of its products. If you have any questions about the product's use or, operation, please contact BT Lab Systems at the following:

E-Mail: info@BTLabSystems.com