

Digital Magnetic Stirrer Hotplate

Cat. No. BT1009

Thanks for choosing BT Lab Systems' BT1009 Digital Magnetic Stirrer Hotplate. This operation manual describes the function and operation of the instrument. In order to use the instrument properly, please read this manual carefully.

IMPORTANT SAFETY INFORMATION

Users should understand how to use the instrument properly before operating it. Please read this operation manual carefully before using the instrument.

The operation, maintenance and repair of the instrument should comply with the basic guidelines and warning below. Ignoring these instructions will affect the life of the Instrument and safety precautions.

- This product is an indoor Instrument which conforms to Standard B style- I type- GB9706.1.
- These units are designed for laboratory use by persons knowledgeable in safe laboratory practices.
- The operator should never open or repair the instrument. Opening or repairing the instrument will void the guarantee and can cause accidents.
- The power plug should safeguard against an electric shock. Make sure the power supply voltage matches the voltage that the instrument needs.
- The instrument should be used in an area with low temperature, little dust, no water, no sunshine or hard light and with good air circulation. Do not use where there is corrosive gas or a strong magnetic field. Keep far away from central heating, camp stove and other hot sources. Do not put the instrument in a wet and dusty area. The vent on the instrument is designed for aeration. Do not wall up or cover the vent.
- Power off when not in use. If the instrument will not be used for a long period, unplug, and cover with a piece of cloth to protect it from dust.
- In case of the following, unplug the instrument at once and contact BT Lab Systems.
 - The instrument comes into contact with liquid
 - The instrument gets soaked or burned
 - The instrument emits an abnormal sound or smell
 - The instrument is dropped or the outer shell damaged
 - The instrument functions abnormally.

MAINTENANCE

The instrument and the accessories should be cleaned with a cloth dampened by alcohol. If there are smudges on the instrument, clean it with a dry cloth.

INTRODUCTION

The heating plate of the digital magnetic stirrer hot plate is made of a special ceramic. With a special heating technique, the heating plate can reach temperatures up to 340°C. It is used in industries of medical science, biochemistry, biology, chemistry, etc.

KEY FEATURES

- The heating plate is made of a special ceramic, making it an easy cleaning feature
- Special heating technique, the heating plate can reach temperatures up to 340°C.
- Safety independent circuit, automatically stops heating when the temperature is over 350°C.
- When the temperature is over 70°C, a hot indicator flickers to remind user.
- PID for temperature control. Two display windows. High precision measurement. Single button operation.
- Use for heating and stirring standard/non-standard reaction flasks from 50ml to 1000ml.
- DC brushless motor makes stable operation with low noise, long life and no sparking.
- Metal plate shell, durable, temperature stable and corrosion-resistant
- The control panel is designed with a 30° slope for convenient operation.
- Magnetic stirring technology. Steady operation at low speed, powerful operation at high speed.

NORMAL OPERATING CONDITIONS

- Ambient Temperature: 4°C ~45°C
- Relative Humidity: ≤70%
- Power: AC110V 10A

TECHNICAL SPECIFICATIONS

Specification	Cat. # BT1009
Diameter of Heating Plate	φ137mm
Heating Plate Material	Ceramic
Motor Type	DC Brushless Motor
Motor Input Power	15W
Speed Range	100 ~1800 rpm
Temperature Range	R.T. +5 ~340 °C (Display Min Temp: 30°C)
Max. Time Setting	-
Stirrer Point	1
Max. Stir Capacity (H ₂ O)	3 L
Stir Bar Size	8 x 50 mm
Heating Output Power	600 W
External Temperature Sensor	PT 1000
Min. Adjusted Safety Temperature Loop	50 °C
Max. Adjusted Safety Temperature Loop	350 °C
Dimension (WxDxH)	270×156×90 mm
Net Weight	2.3 kg
Voltage	110V AC
Frequency	50-60 Hz

EQUIPMENT OVERVIEW

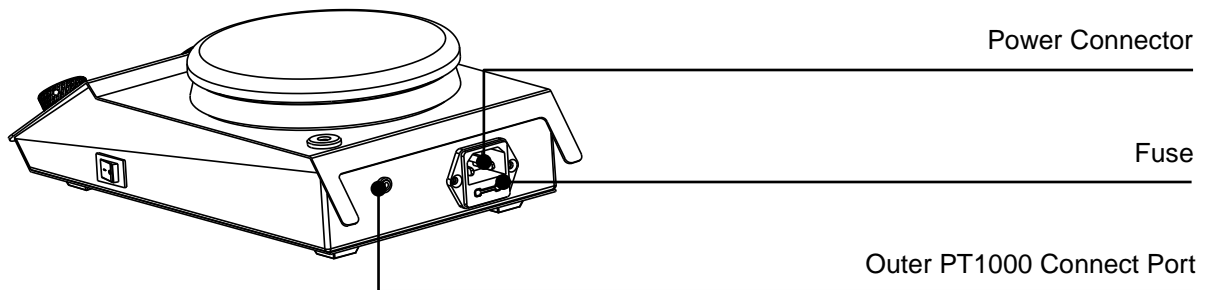
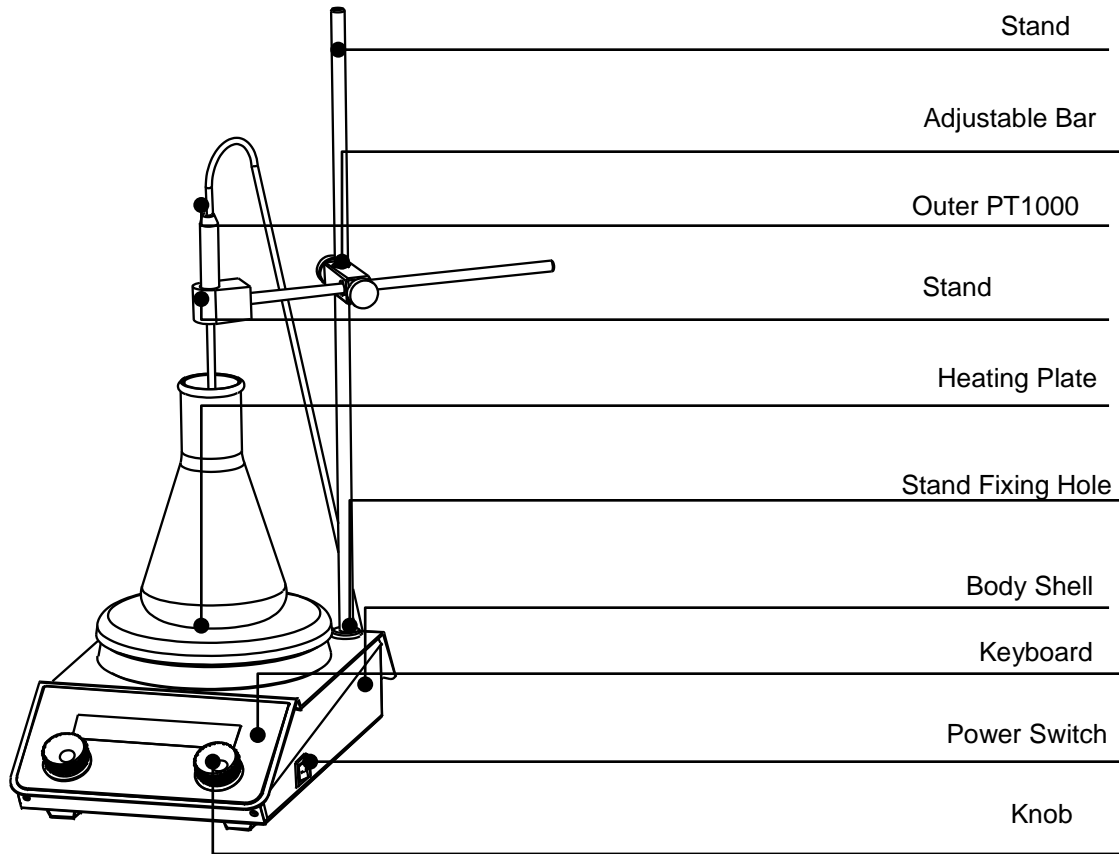

Keyboard and Display Panel

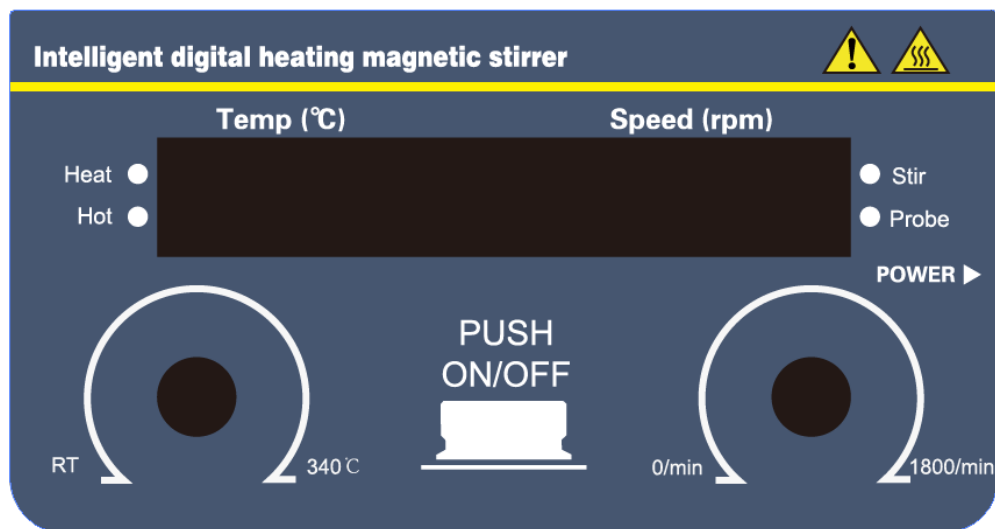

KEY FUNCTION

Rotate the right knob clockwise to increase speed/time. Rotate the knob counterclockwise to decrease speed/time. Press the knob to start operation.

Rotate the left knob clockwise to increase temperature. Rotate the knob counterclockwise to decrease temperature. Press the knob to start operation.

OPERATION GUIDE

Speed, Timing and Temperature Setting

1. Switch on the instrument, LED will display "8". The instrument will beep.
2. The speed LED displays the last running speed. Rotate the speed knob clockwise to increase the speed. Rotate the speed knob counterclockwise to decrease the speed. For BT1010 time setting is the same as above.
3. The temp LED displays the last temperature setting. Rotate the temperature knob clockwise to increase the temperature ng value. Rotate the temperature knob counterclockwise to decrease the temperature value.
4. The instrument allows setting new target value while the instrument is operating (without pressing the key to stop the program).
5. When heating plate is over 50°C, the indicator of "hot" will stay lit to remind user of hot plate to avoid injury.
6. The indicator light "heat" flickers when it is heating. The indicator of "heat" stays lit when instrument is holding temperature.

The indicator of "stir" stays lit when stirrer is working.

The indicator of "probe" lights when it displays temperature from outer PT1000.

Stop / Start

1. Press knob for speed to start mixing. Press it again to stop mixing with beep alarm.
2. Press knob for temp. to start heating. Press it again to stop heating with beep alarm.

TROUBLE SHOOTING

Issue	Possible Causes	Solution
No signal display when the power is on.	No power	Check the power
	Broken switch	Exchange the switch
	Other	Contact BT Lab Systems
Shaking heavily	Sample not put in the center	Place the sample in center position
Actual speed and displayed speed are not matching	Broken controller	Contact BT Lab Systems
Err displays	Speed out of control	Contact BT Lab Systems
No heating from heating plate	Broken temperature sensor –Broken heating wire	Contact BT Lab Systems
Knob not working	Broken knob	Contact BT Lab Systems

WARRANTY

The instrument is warranted against defects in materials and workmanship for 1 year. If any defects occur in the instrument or accessories during this warranty period, BT Lab Systems will repair or replace the defective parts at its discretion without charge.

For any inquiry or request for repair service, contact your local BT Lab Systems office. Inform BT Lab Systems of the model and serial number of your instrument.

TECHNICAL SUPPORT

BT Lab Systems offers technical support for all of its products. If you have any questions about the product's use or, operation, please contact BT Lab Systems at the following:

E-Mail: info@BTLabSystems.com